

Quolis[®] Series

Quolis 5000 Chair

Model Q-5000

INSTALLATION INSTRUCTIONS

IMPORTANT

This manual provides installation instructions for the Quolis Chair.

The instructions contained in this booklet should be thoroughly read and understood before operating the chair.

After the installation has been completed, keep this manual in a safe place and refer to it for future maintenance.

 **Belmont[®]**

TABLE OF CONTENTS

	Page
1. OVERVIEW AND MAJOR COMPONENTS-----	1
2. DIMENSIONS AND SPECIFICATIONS-----	2
3. INTRODUCTION	
3-1. Precautions For Installation-----	3
3-2. Required Tools-----	3
4. UNPACKING OF CHAIR-----	4
5. INSTALLATION-----	5
5-1. Positioning The Chair-----	5
5-2. Attaching The Chair Base To The Floor-----	6
5-3. Attaching The Backrest-----	7
5-4. Attaching The Headrest-----	8
5-5. Attaching The Seat-----	8
5-6. Attaching The Armrest-----	9
6. SPEED ADJUSTMENT -----	10
7. HYDRAULIC DIAGRAM-----	11
8. ELECTRICAL DIAGRAM-----	12

Intended Use of the Product

This product is intended for the exclusive use for diagnoses, treatments and relative procedures of dentistry, and must be operated or handled by the qualified dentists or by dental staffs under the supervision of the dentist.

Such dentists or dental staffs should instruct and/or assist the patients to approach to and leave from the product.

Patients should not be allowed to operate or handle the product unless he/she is so instructed.

Environmental Requirements

Operating	Ambient Temperature	50°F ~ 104°F (10°C ~ 40°C)
	Humidity	30% ~ 75%
	Atmospherical Pressure	10.2psi ~ 15.4psi (700hpa ~ 1060hpa)

Classification

- a. Protection against electric shock : Class I Equipment, Type B Applied Parts 
- b. Protection against water ingress : Ordinary equipment (IPX0)
- c. Equipment not suitable for use in the presence of a flammable anesthetic mixture with air or with oxygen or nitrous oxide.

1. OVERVIEW AND MAJOR COMPONENTS

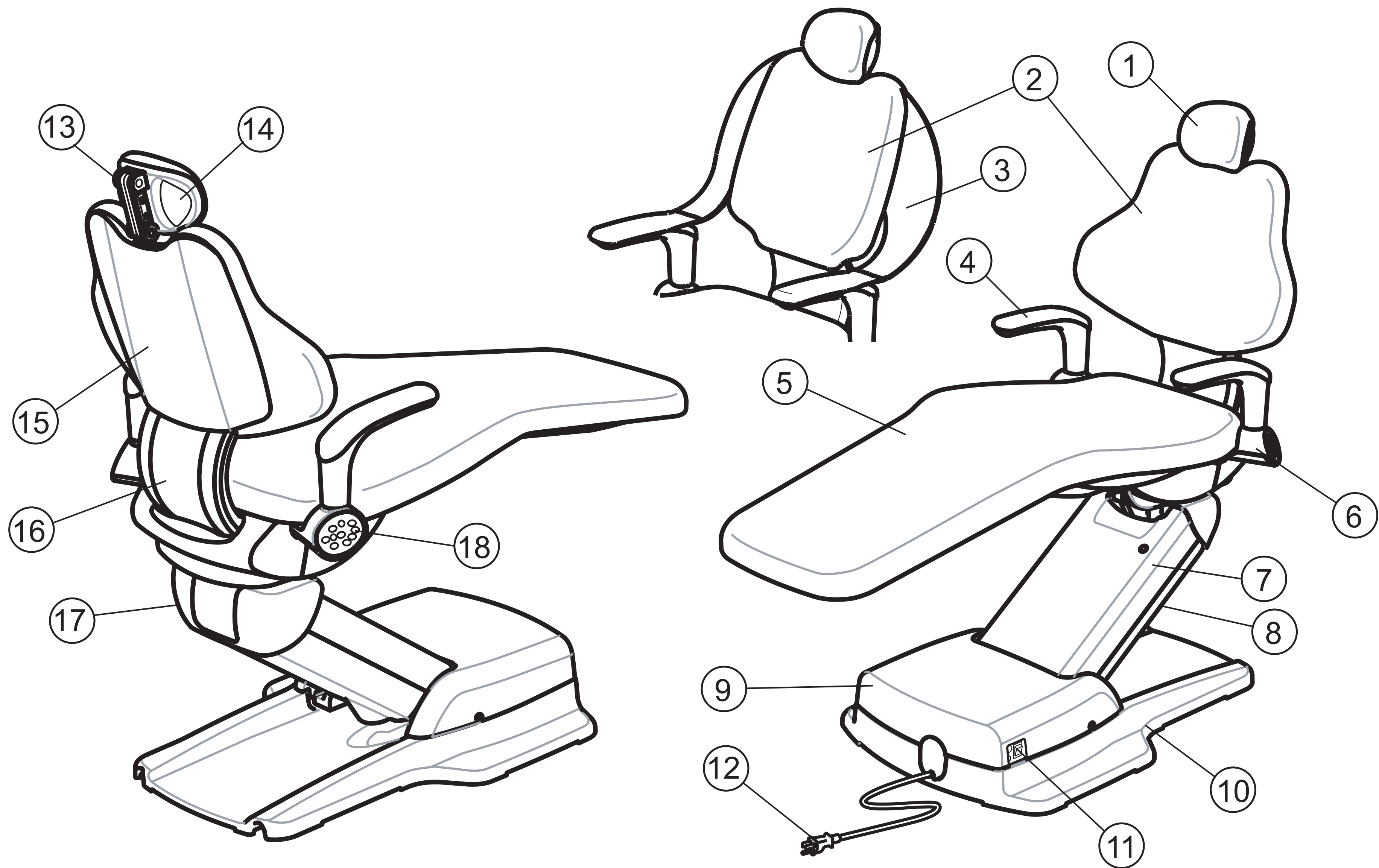

Fig.1-1 Overview

- | | |
|-------------------|---------------------------|
| 1 Headrest | 10 Base |
| 2 Backrest | 11 Main Switch Panel |
| 3 Sling | 12 Electrical Plug |
| 4 Armrest | 13 Headrest Assembly |
| 5 Seat | 14 Headrest Cover |
| 6 Armrest Bracket | 15 Backrest Cover |
| 7 Main Link Cover | 16 Back Support |
| 8 Sub Link Cover | 17 Flange |
| 9 Pump Cover | 18 Touchpad Control Panel |

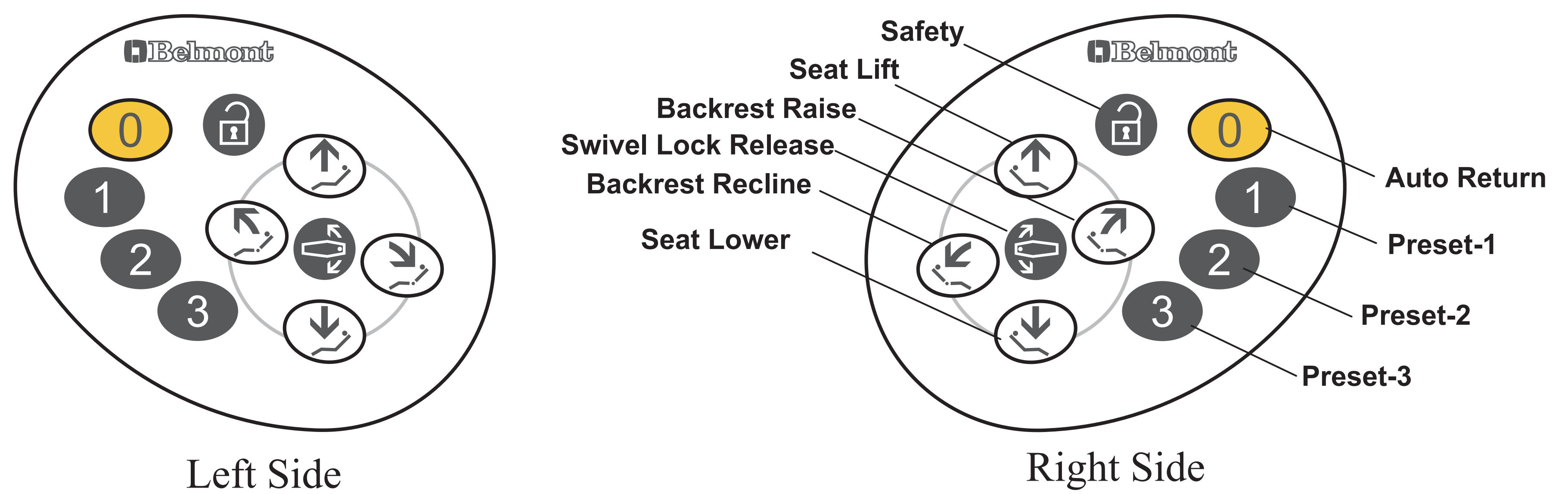

Fig.1-2 Touchpad Control Panel

2. DIMENSIONS AND SPECIFICATIONS

2-1. Dimensions

-inch-

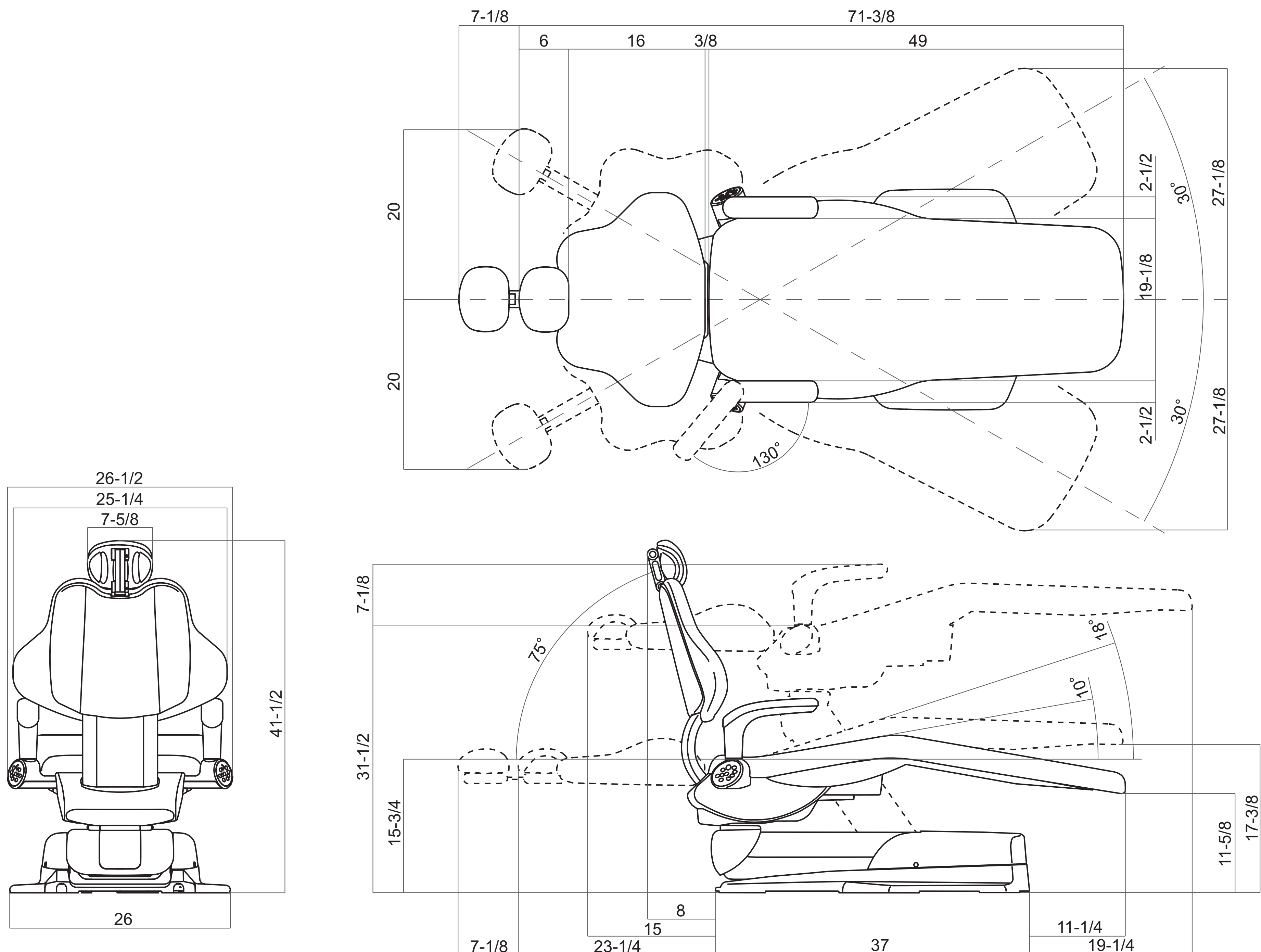

Fig.2-1 Dimensions

2-2. Specifications

Seat Initial Height	-----	15-3/4"(400mm)
Seat Lifting Stroke	-----	15-3/4"(400mm)
Backrest Movement	-----	0°~75° (above Horizontal)
Tilting Mechanism	-----	Backrest Synchronized Tilting (10°~18°)
Seat Rotation	-----	30° Left / 30° Right of Centerline
Auto Movements	-----	3-Preset, and 1 Auto Return
Electrical Requirement	-----	120V ~ 60Hz, 3.8Amps
Control Voltage	-----	DC5V
Mode of Control	-----	3min (Short-Time Operation)
Chair Lifting Capacity:		
Patient Load	-----	297lbs.(135kgf) maximum
Accessory Load	-----	165lbs.(75kgf) maximum
Weight	-----	297lbs.(135kgf)

3. INTRODUCTION

3-1. Precautions For Installation

- The floor construction required to safely support the chair and delivery system is 105 lbs./ft² (500kg/m²) at minimum.
- During lifting and unpacking of the chair, make sure to hold only the designated parts.
- Do not drop or hit the chair.
- After the chair is unloaded from the palette and placed at the desired location, please make sure to remove the shipping bolt with the red tag. Damage to chair may occur if shipping bolt is not removed prior to chair operation.
- Do not connect to power supply other than 120V 60HZ.
- Ground chair properly prior to turning power on.
- Chair base must be anchored to the floor for maximum stability.
- Refer to the installation manual of the chair and dental unit (if it is to be used) prior to, and during installation.
- When the installation process has been completed, verify that all the mechanical and electrical functions are working properly and that there is no evidence of oil leakage.

3-2. Required Tools

The following tools are necessary for installation of the chair:

- Philips screw drivers (No.1, No.2)
- Flat screw driver
- Wrenches (open end): 8mm, 10mm, 17mm
- Hex key wrenches: 2.5mm, 6mm, 8mm
- Socket wrench with ratchet drive 17mm

4. UNPACKING OF CHAIR

The chair packaging consists of two boxes:

Box **1**: Chair base section

Box **2**: Upholstery section

After unpacking, make sure all components can be located.

⚠ CAUTION

Knives or sharp objects may damage package contents. Open with care!

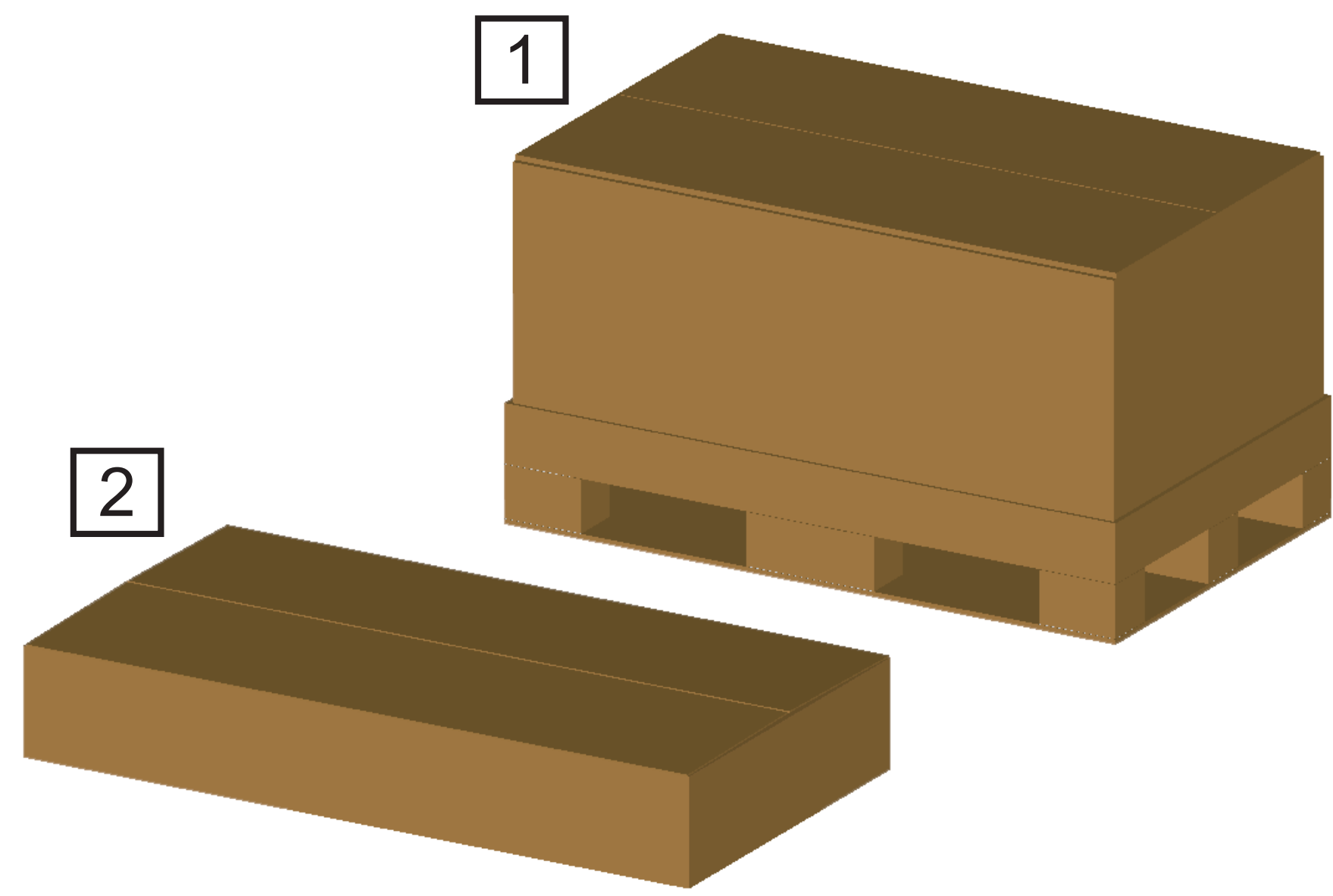

Fig. 4-1

Box 1 : Chair base section

- (1) Chair base assembly----- 1
- (2) Backrest assembly----- 1
- (3) Headrest mechanism----- 1
- (4) Headrest cover----- 1
- (5) Arm rest assembly----- 1 set
- (6) Installation hardware box with the following:
 - 9 x 65mm Hex head Anchor bolts----- 2 pcs.
 - M8 x 20mm Socket head screws----- 4 pcs.
 - M6 x 25mm Pan head Phillips screws----- 2 pcs.
 - M5 x 10mm Round head Phillips screws----- 6 pcs.
 - M5 x 10mm Flat head Phillips screws----- 3 pcs.
 - 4 x 10mm Pan head Phillips wood screw----- 1 pc.
 - Pump Cover Cap ----- 1 pc.
 - Plastic Cap (for link cover)----- 1 pc.

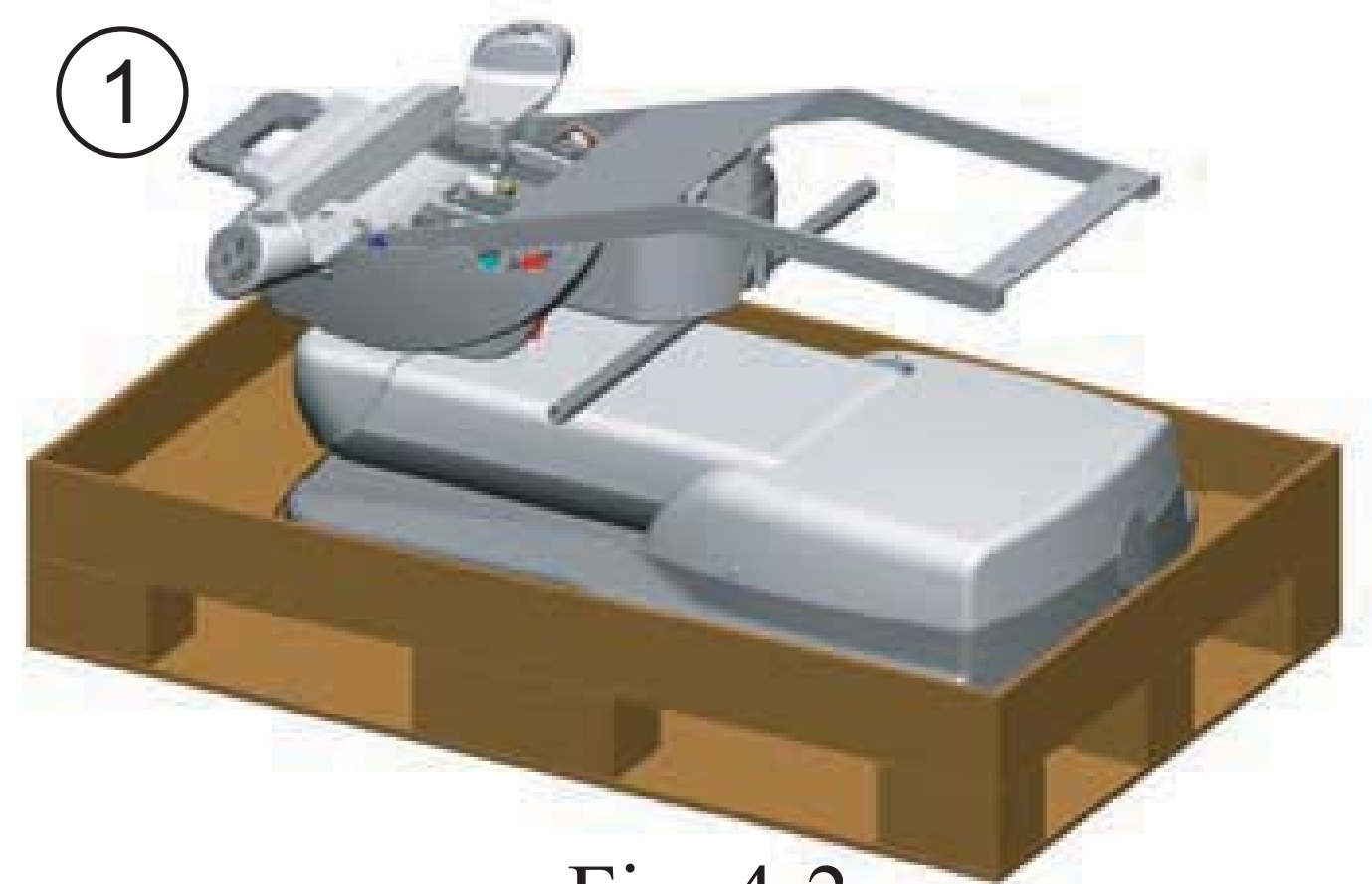

Fig. 4-2

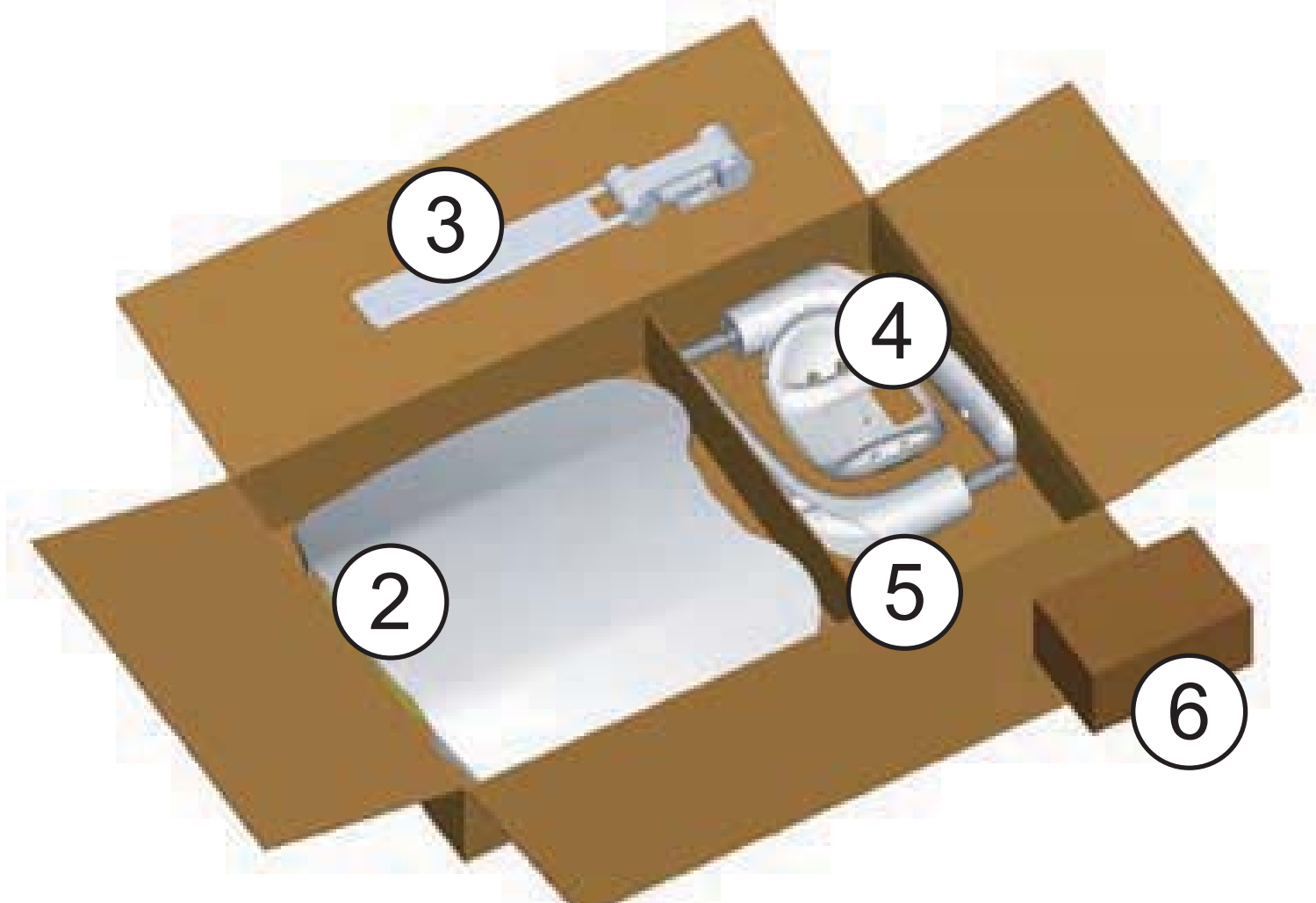

Fig. 4-3

Box 2 : Upholstery section

- (7) Seat cushion----- 1
- (8) Backrest cushion----- 1
- (9) Headrest cushion ----- 1
- (10) Armrest cushions----- 1 set

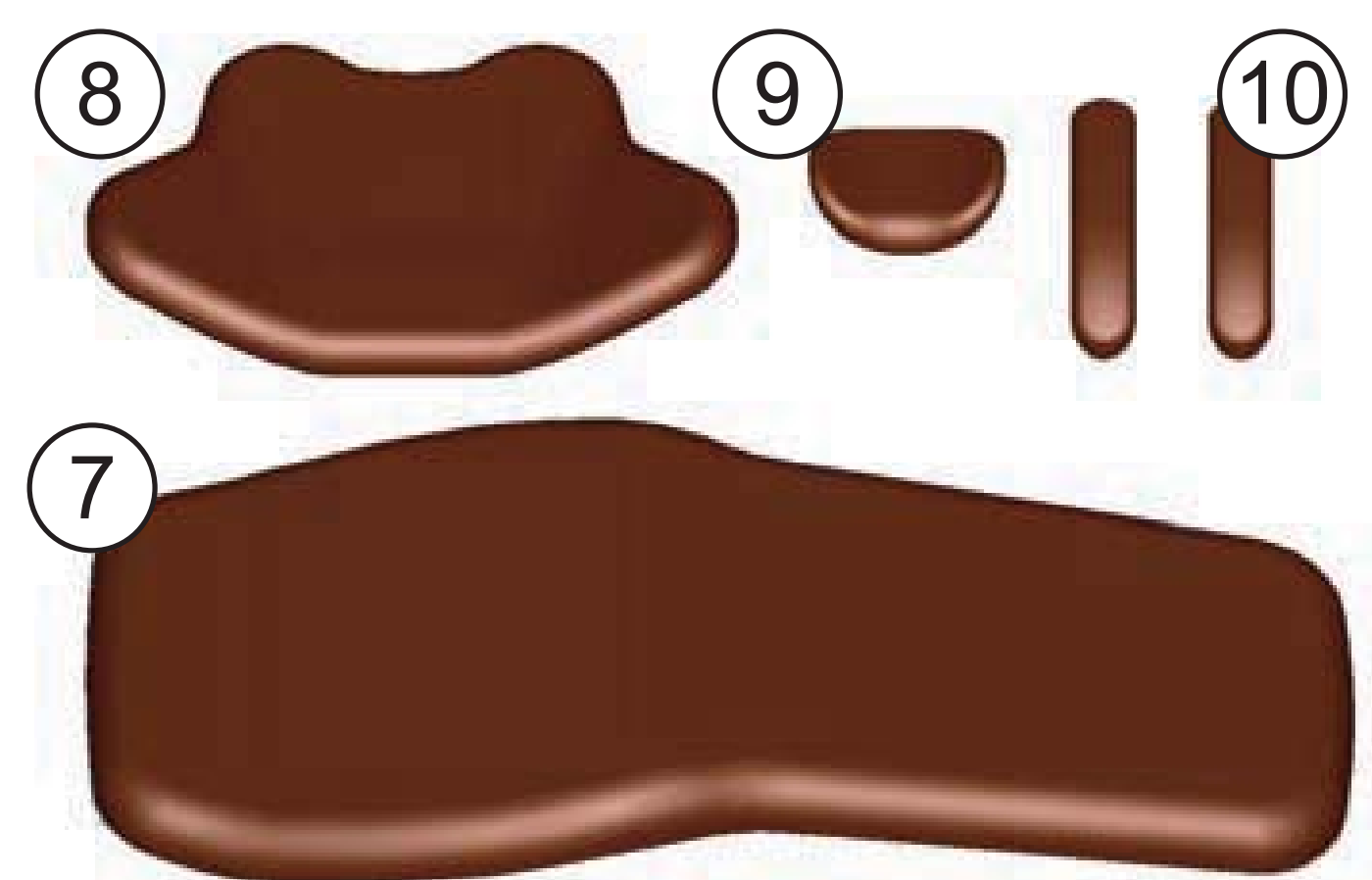

Fig. 4-4

5. INSTALLATION

5-1. Positioning The Chair

⚠ CAUTION

Do not connect in the power supply line before removing the red tagged Shipping Bolt.

1. Remove the Chair Base Section from the pallet by holding the Armrest Bracket and Lifting Bar and place it at the planned location. (Fig. 5-1)
2. Remove the red tagged Shipping Bolt (M10x150mm) from the chair. (Fig. 5-2)

⚠ CAUTION

Do not lift the chair by the upper structure after removal of the red tagged Shipping Bolt.

3. Plug chair into a 120V AC outlet.
4. Turn the Main Power Switch on and raise the chair up. (Fig. 5-3)

Note: Refer to the Operation Manual for chair to operate.

5. Remove the pump cover by removing two slotted screws (M5x10mm) from each side of the pump cover. (Fig.5-3)
6. Remove the red tagged Oil Plug from the Oil Reservoir. (Fig.5-4)
7. Remove the Lifting Bar from the chair by removing two M10x30mm bolts. (Fig.5-4)

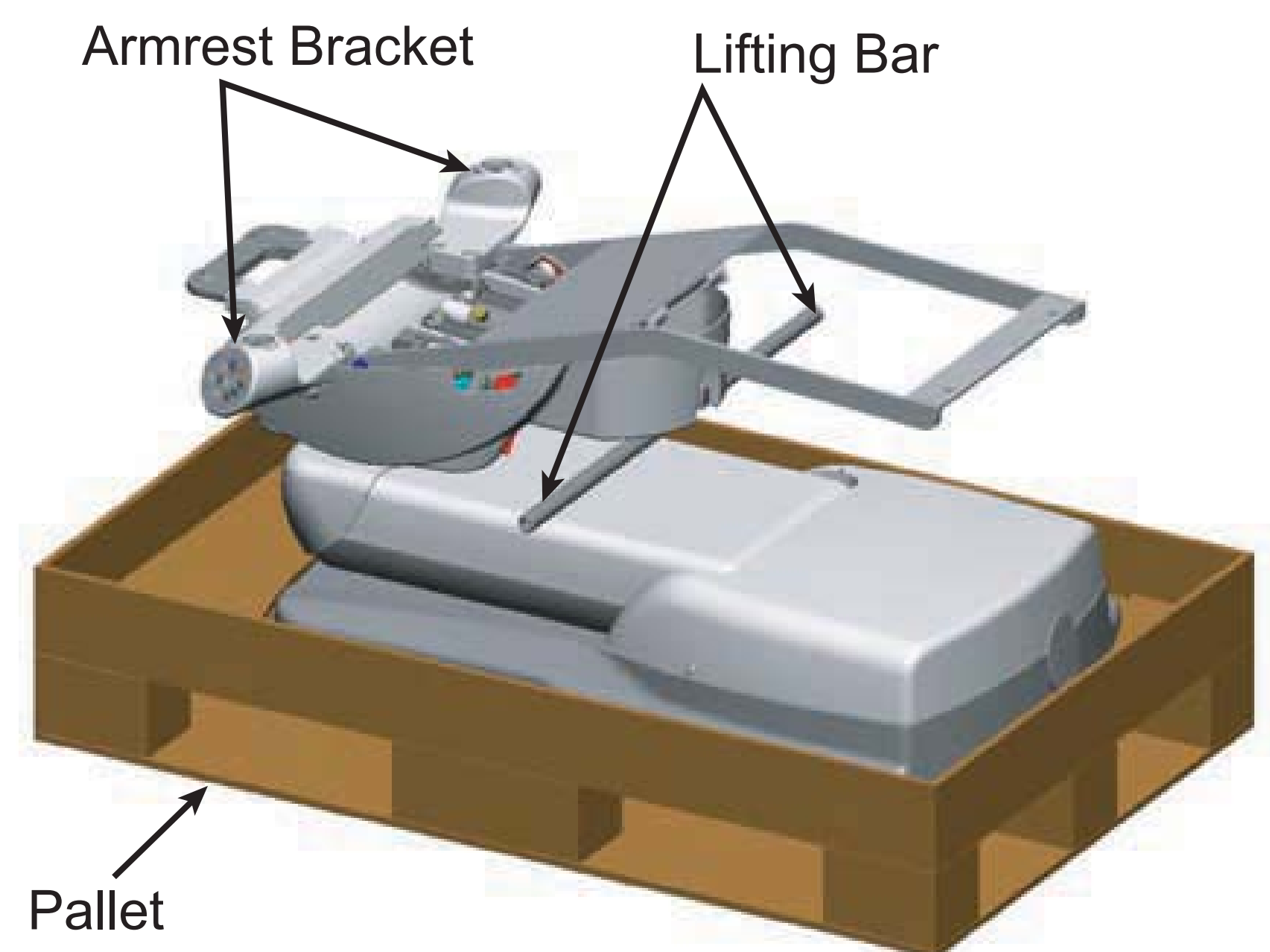

Fig. 5-1

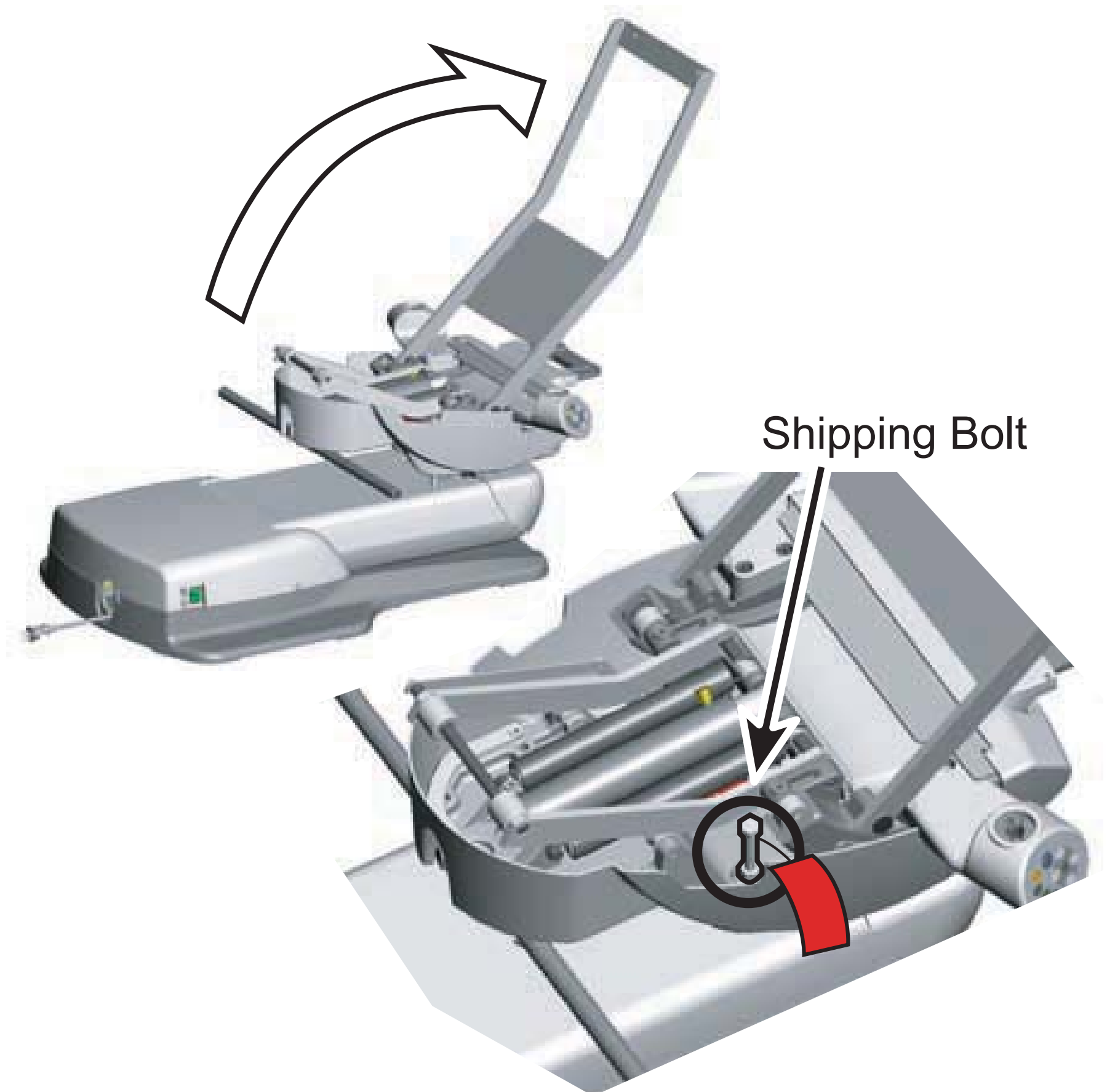

Fig. 5-2

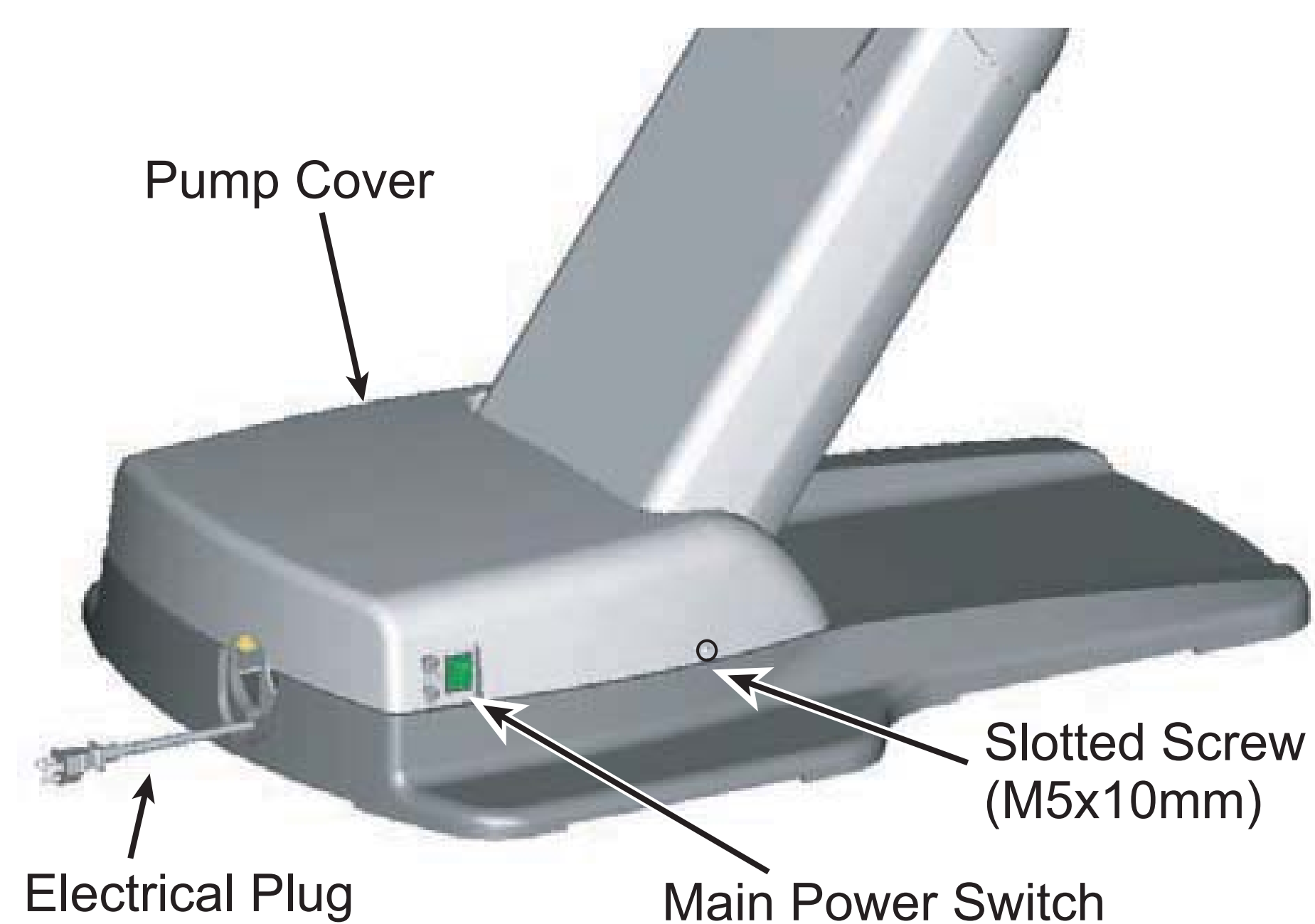

Fig. 5-3



Fig. 5-4

5-2. Attaching The Chair Base To The Floor

Attach the chair base to the floor using the two anchor bolts (9x65mm). (Fig.5-5, 5-6)

⚠ CAUTION

Attach the chair base to the floor prior to installation of the Quolis dental unit.
(if it is to be installed on chair)

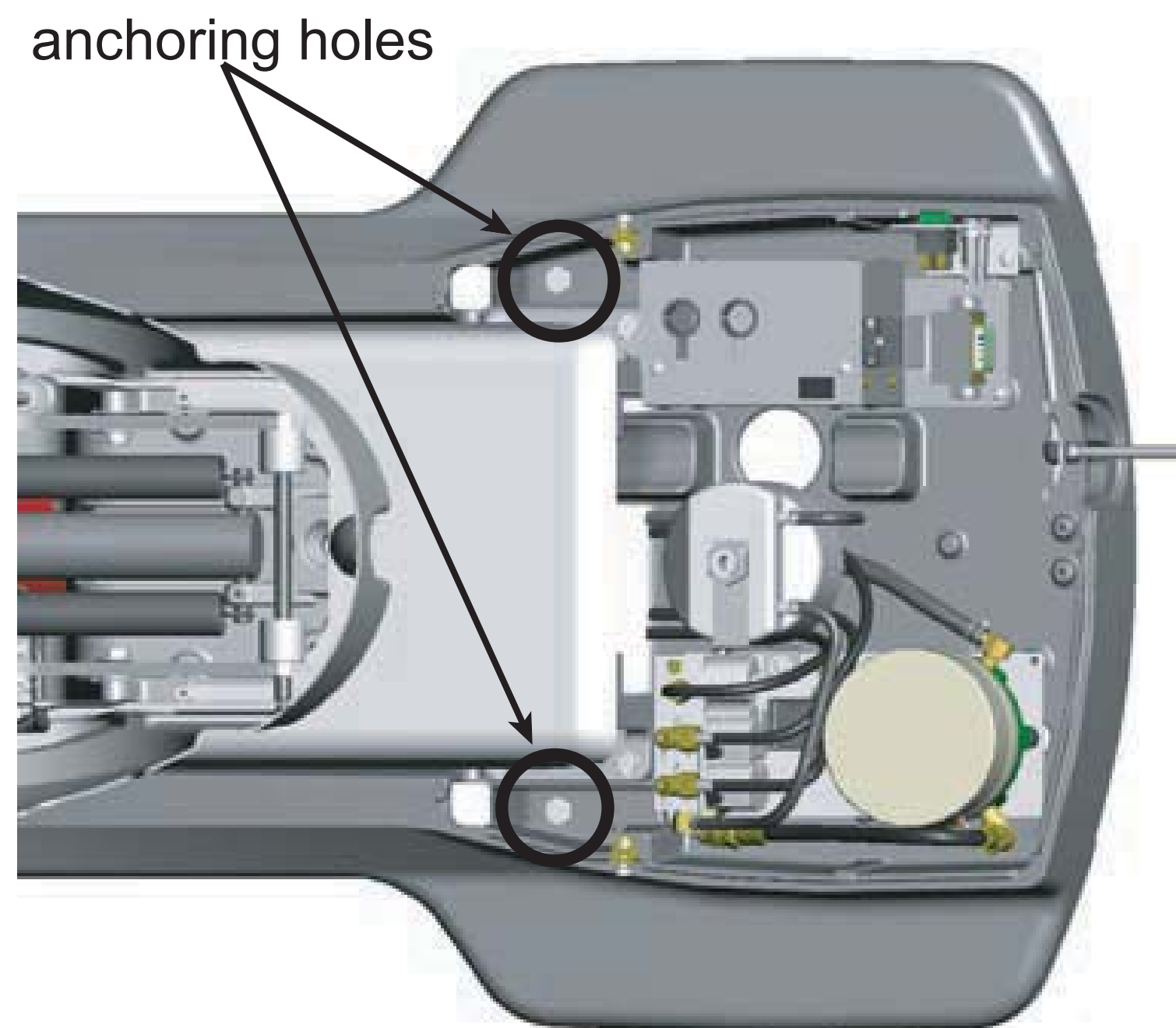

Fig. 5-5

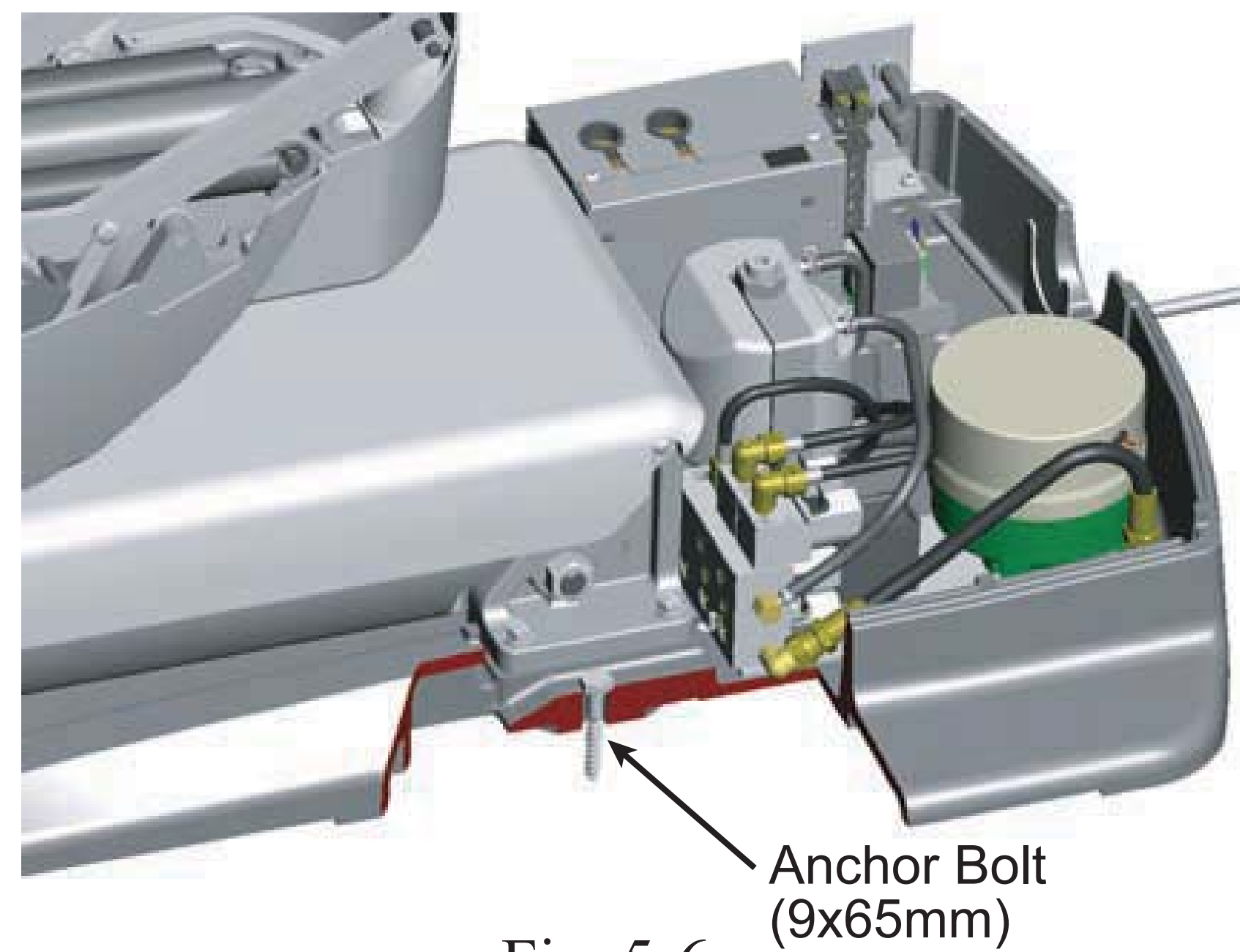

Fig. 5-6

IMPORTANT: If you are going to install Quolis dental unit onto the chair, please refer to the installation manual for the dental unit before proceeding further with chair installation. Resume assembly of the chair after installation of the dental unit onto the chair has been completed.

If you don't use a Junction box, plug the hole by a pump cover cap.

Fix this cover by 4 x 10mm screw. (Fig.5-7)

Attach the Pump Cover to the chair using the two slotted screws (M5x10mm). (Fig.5-8)

Note: Please tighten these screws firmly by a Flat screw driver so that no other personnel than qualified technicians can open the cover.

Insert the plastic cap into the hole on the Main Link Cover. (Fig.5-8)

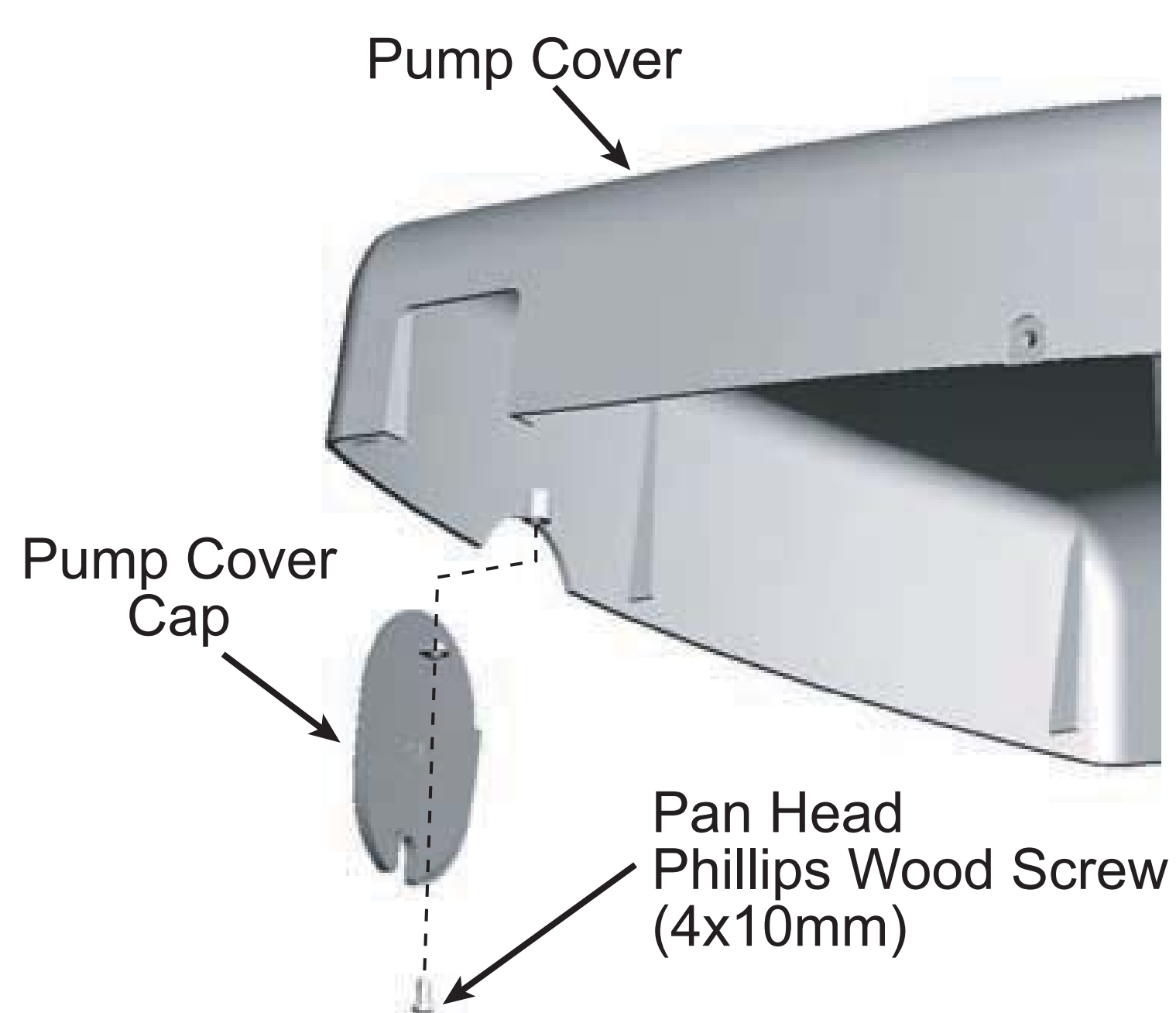

Fig. 5-7



Fig. 5-8

5-3. Attaching The Backrest

1. Attach the Backrest Assembly to the Backrest Support using the four socket head screws (M8x20mm) shipped in the Installation Hardware Box. (Fig.5-6)
2. Attach the backrest cushion to the backrest assembly as follows (Fig.5-7):
 - Align key holes on the backside of the backrest cushion with the 4 hooks on the backrest assembly
 - Press Backrest Cushion against Backrest Assembly, then slide cushion downward to lock in place

Note: Make sure that the cushions are hooked at four places and as illustrated below.

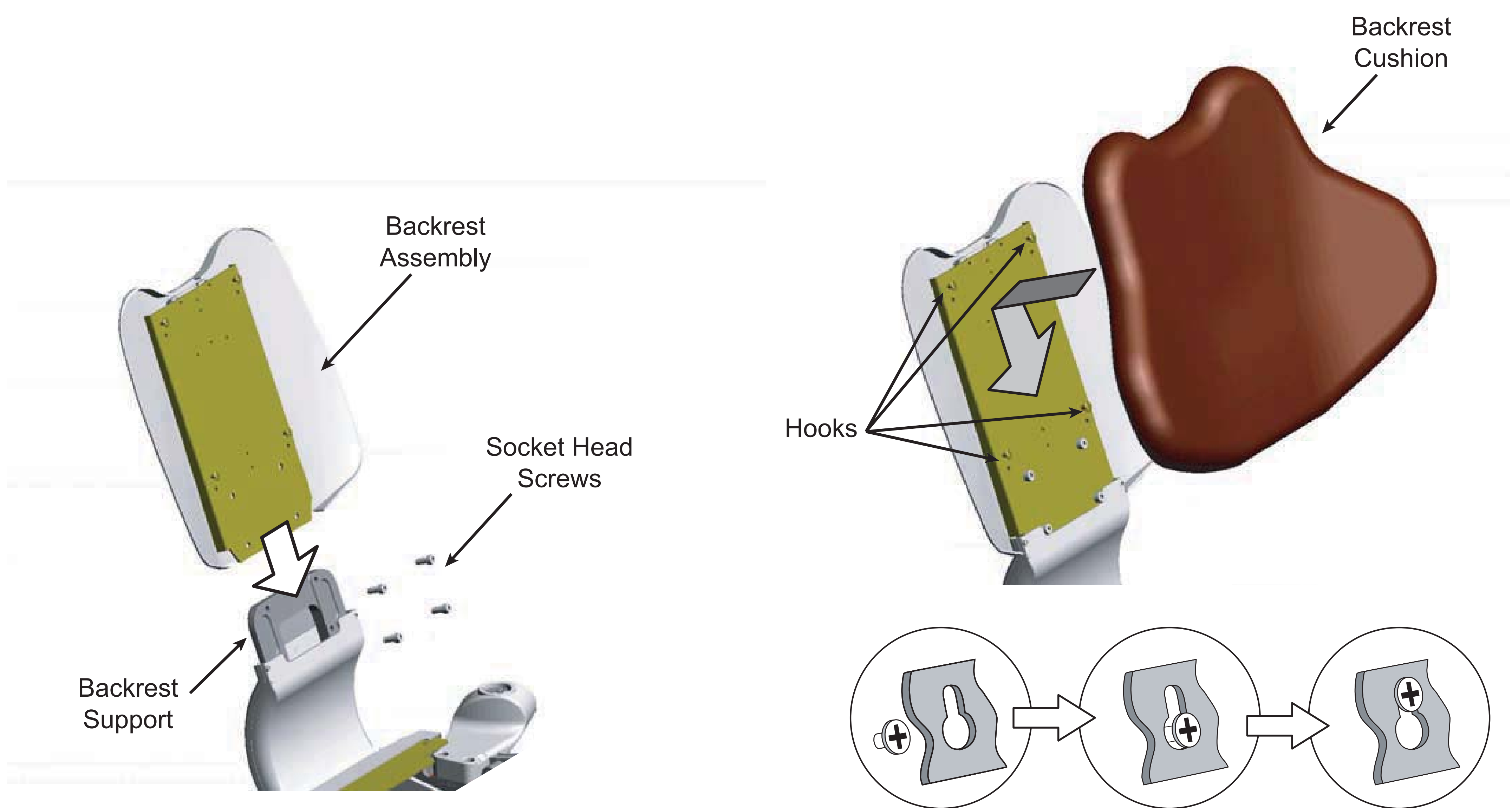

Fig. 5-6

Fig. 5-7

5-4. Attaching The Headrest

1. Attach the Headrest Cushion to the Headrest Mechanism using three flat head phillips screws (M5x10mm) shipped in the Installation Hardware Box. (Fig.5-8)
2. Insert Headrest Mechanism bar through cut-out in Headrest Cover, as shown (Fig.5-8). Slide Headrest Cover over Headrest Mechanism and press firmly together with the Headrest Cushion.
3. Insert the Headrest Assembly into the slot on top of the Backrest Assembly. (Fig.5-9)

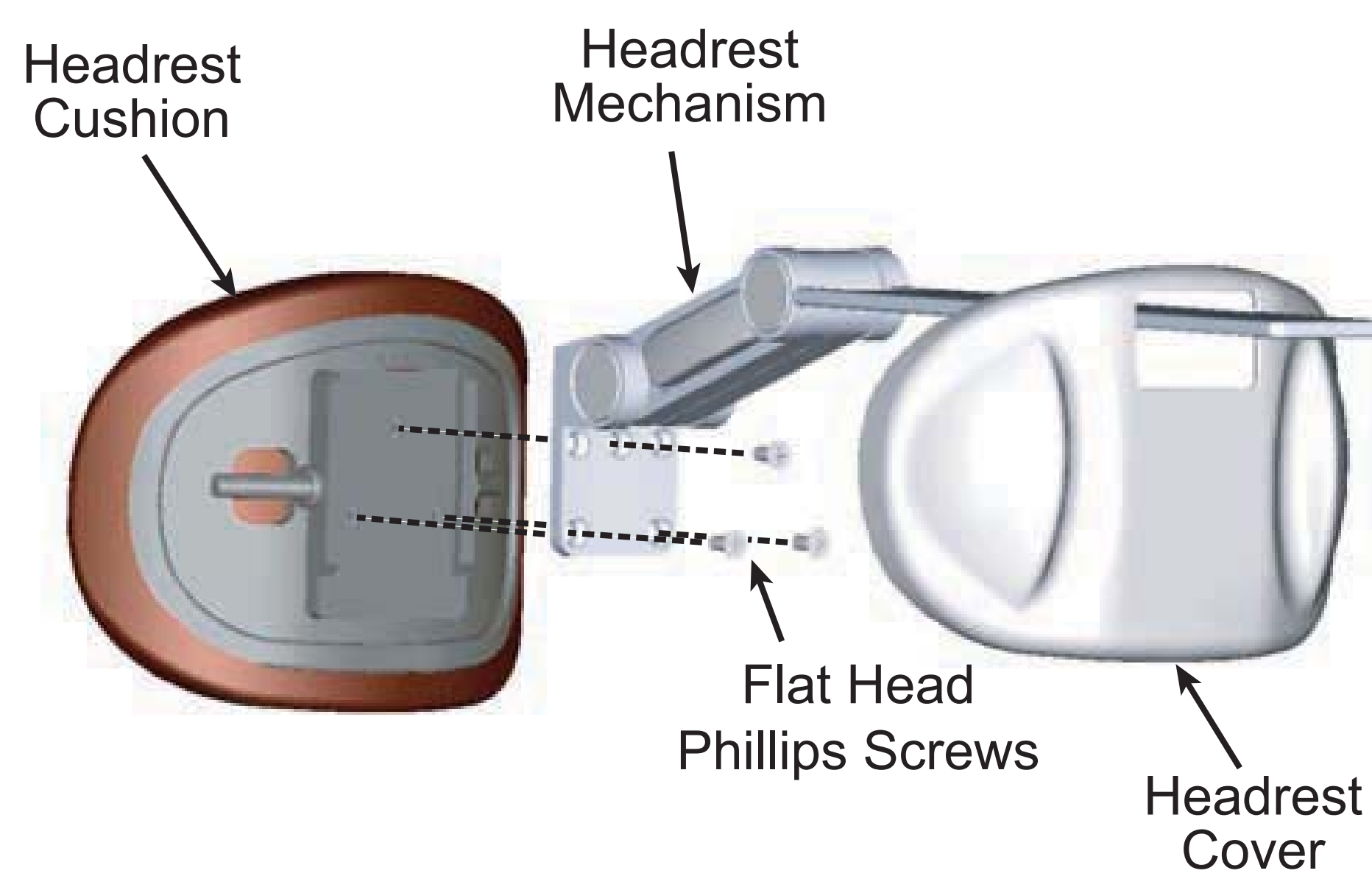

Fig. 5-8

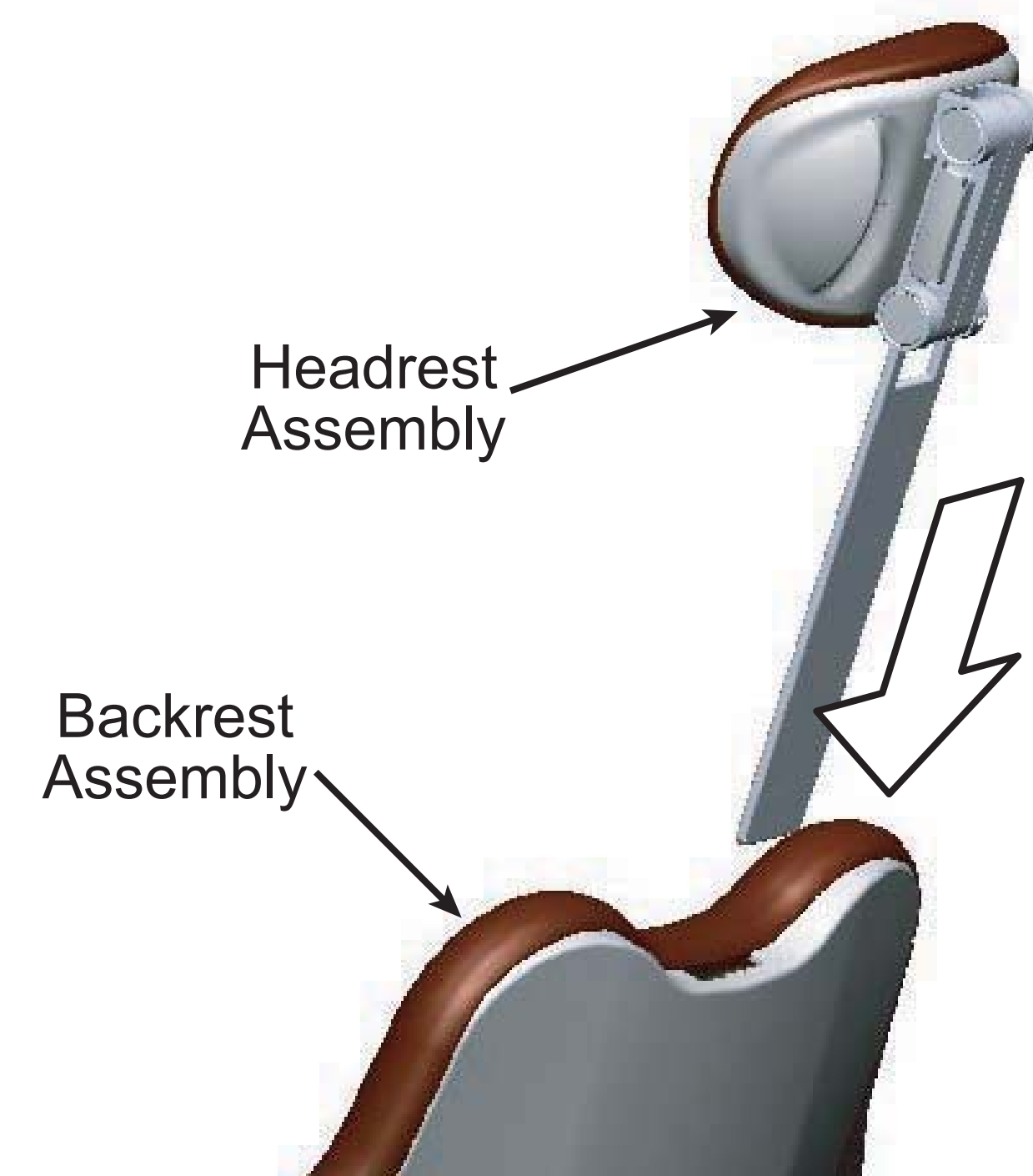

Fig. 5-9

5-4. Attaching the Seat

1. Slide the Seat Cushion onto the chair as shown, to hook onto to chair frame. (Fig.5-10)
2. Secure the front end of the Seat Cushion to the chair frame using the two round head phillips screws (M5x10mm) shipped in the Installation Hardware Box. (Fig.5-11)

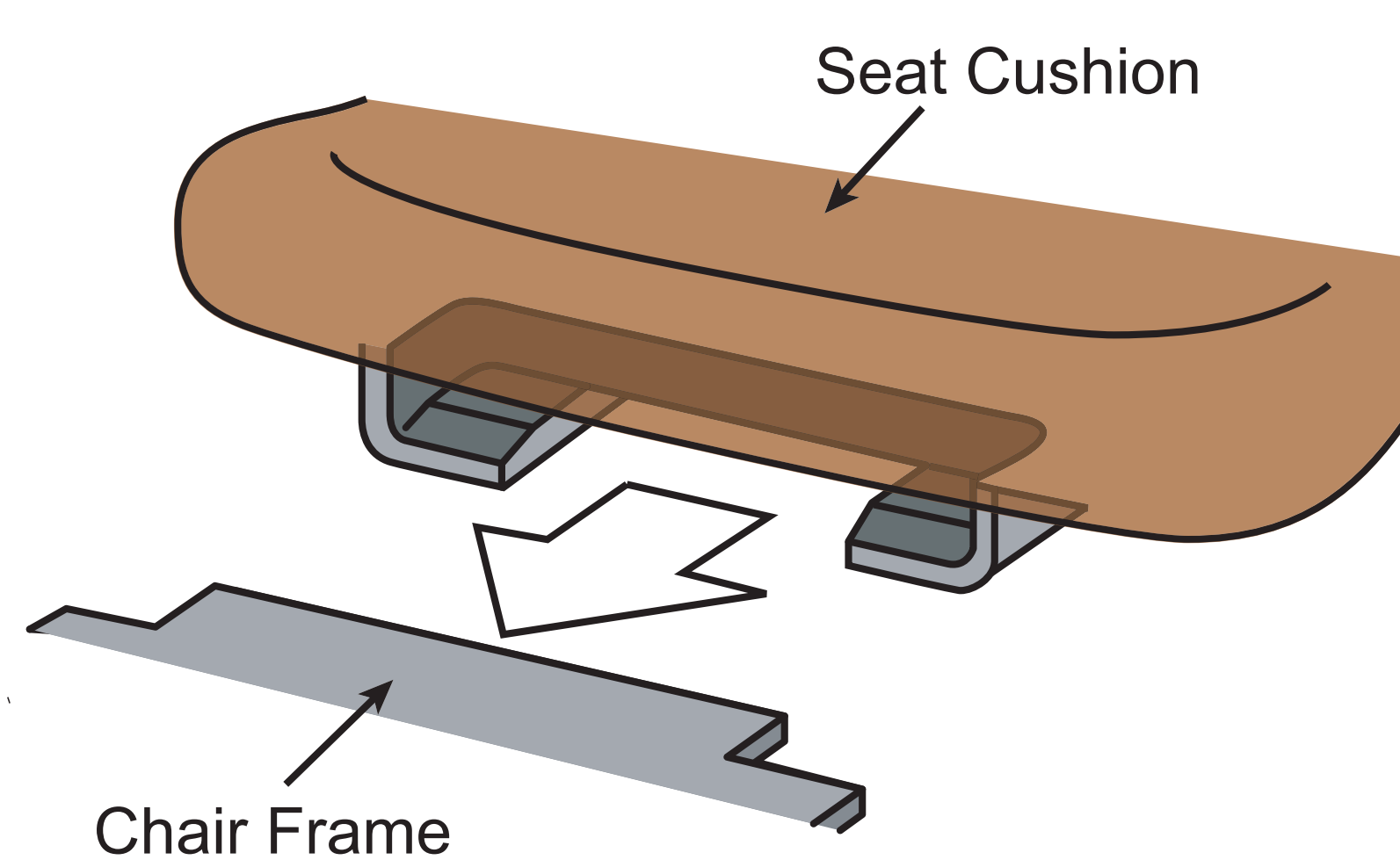

Fig. 5-10

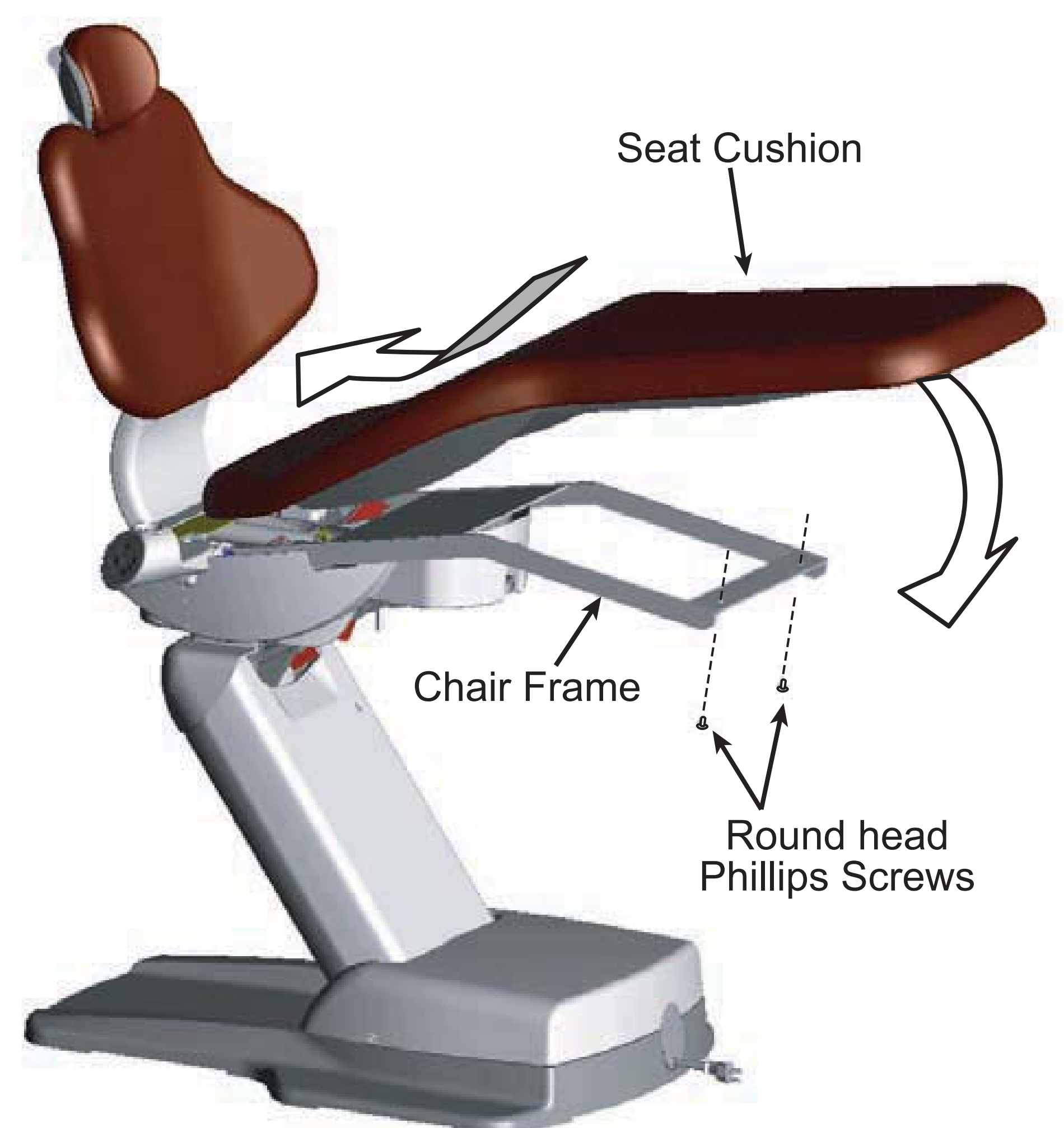

Fig. 5-11

5-6. Attaching The Armrests

1. Insert the Armrest to the Armrest Bracket and attach it with a pan head screw (M6x25mm). After attaching, verify both of the armrests swing outward 130 degrees only. (Fig.5-12)
2. Assemble the Armrest Cushions to the Armrest using two round head screws (M5x10mm) per Armrest Assembly. (Fig.5-13)

If your Quolis chair has a narrow type backrest with slings, slide a sling onto an armrest cushion, then fix an armrest cushion to an armrest by using two screws. (Fig.5-14)

The left and right Armrests and cushions are identical and may be installed on either side of the chair.

3. Remove a protective plastic film on a touchpad control panel. (Fig.5-15)

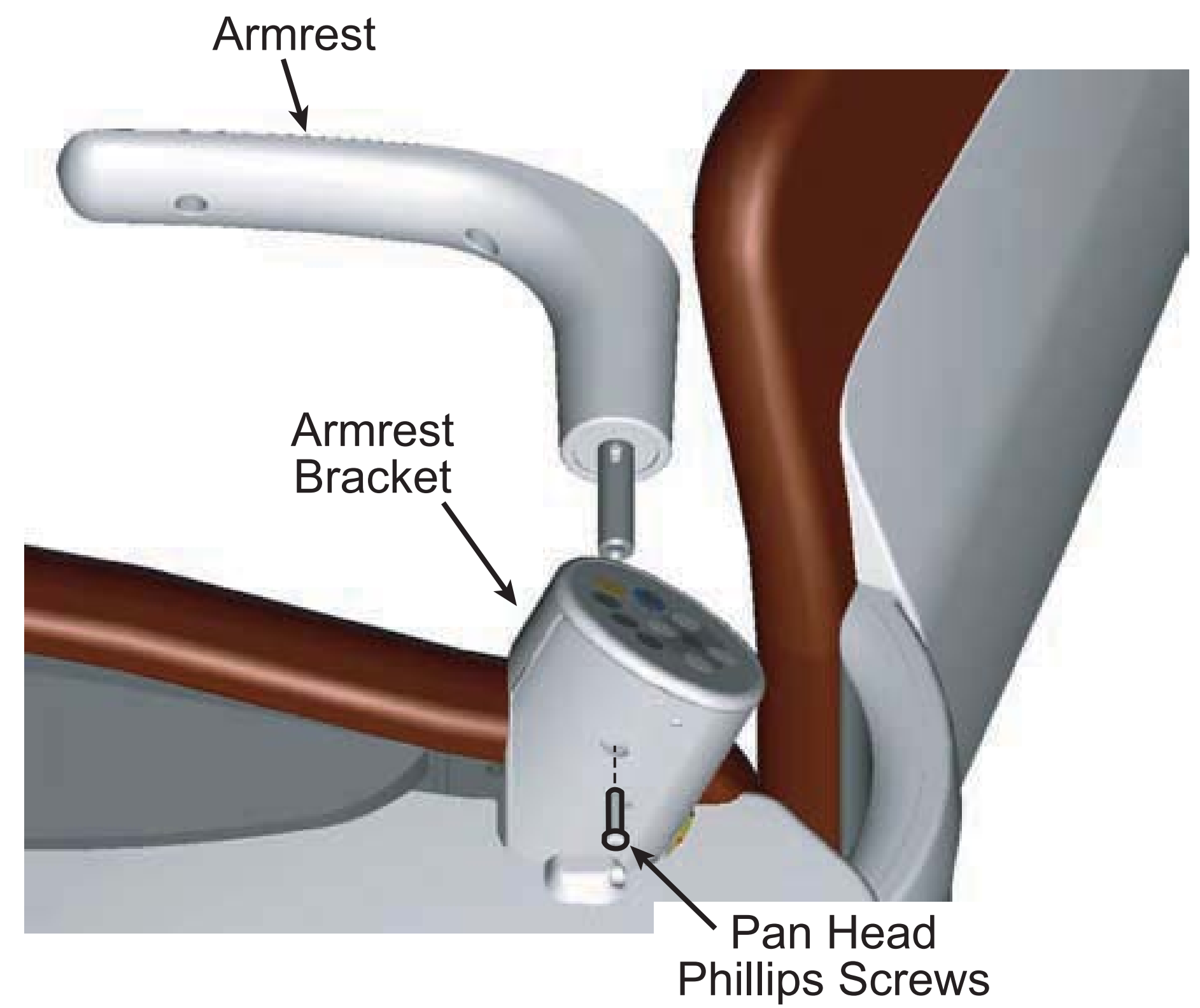

Fig. 5-12

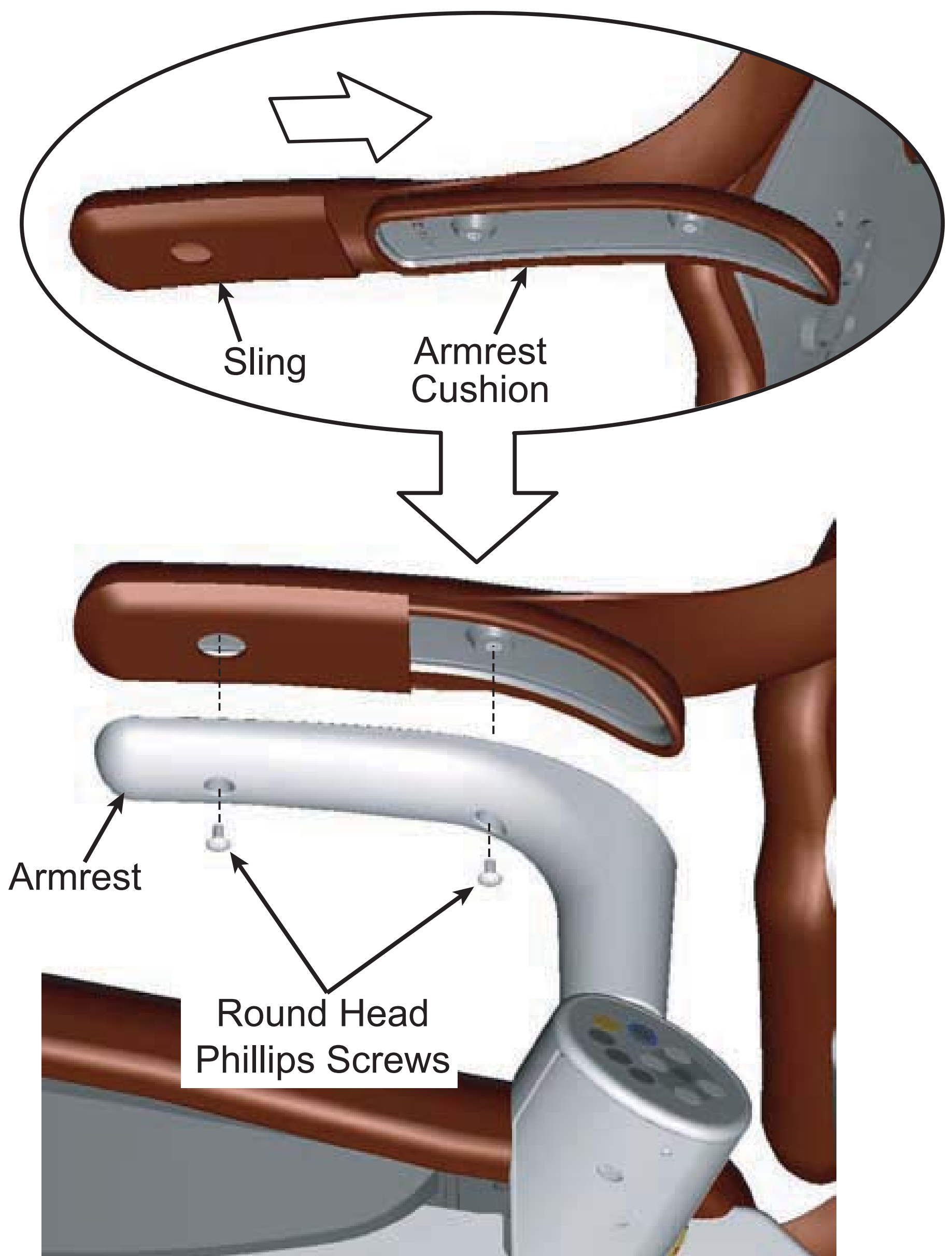

Fig. 5-14

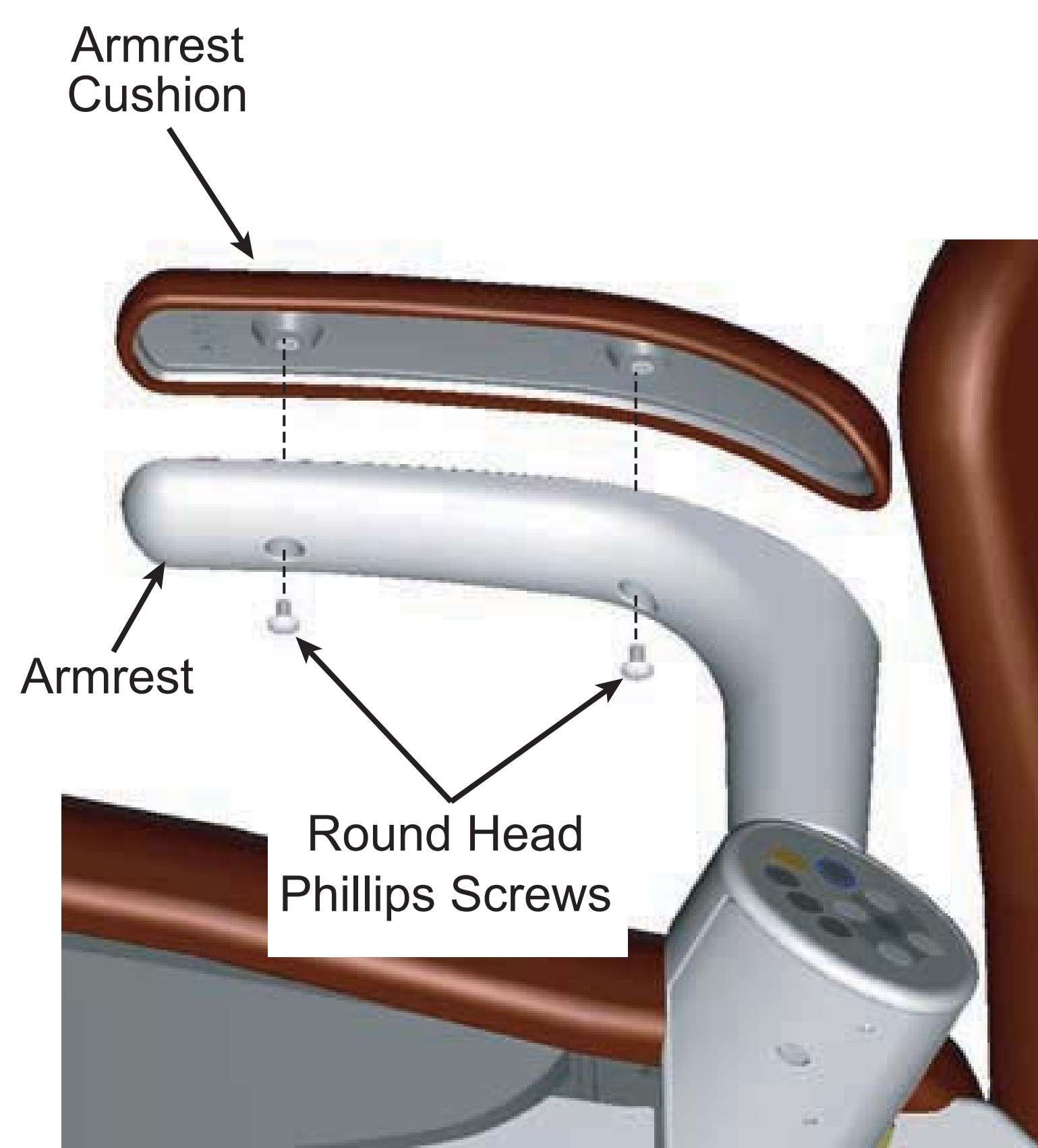

Fig. 5-13



Fig. 5-15

6. SPEED ADJUSTMENT

Seat lowering speed and backrest recline speed can be adjusted with screws on the Solenoid Valve Block.

The Solenoid Valve Block is located inside the pump cover, as shown. (Fig.6-1)

Each solenoid valve corresponds to a specific chair function. (Fig.6-2)

- SV1 : Backrest Raising
- SV2 : Backrest Reclining
- SV3 : Seat Lifting
- SV4 : Seat Lowering
- SV6 : Swivel Brake Release
- SV7 : Seat Shockless
- SV8 : Backrest Shockless

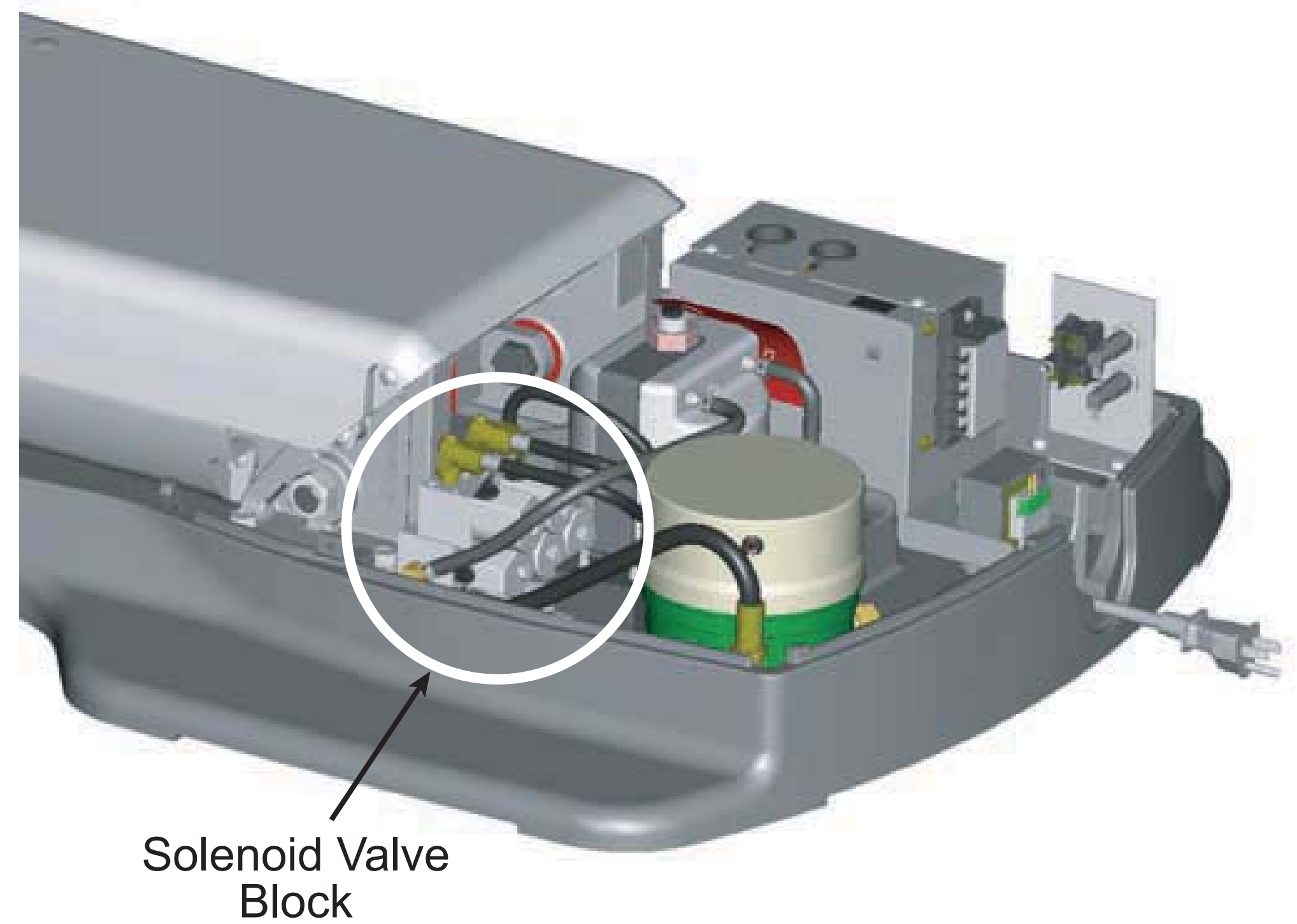

Fig. 6-1

By turning the each speed adjustment screw clockwise, the speed is reduced for the corresponding chair function.

By turning adjustment screws counterclockwise, the corresponding chair function speed is increased. (Fig.6-3)

⚠ CAUTION

The chair movement will be locked if the speed is reduced excessively.
Oil may leak from the speed control knob if the speed is increased excessively.

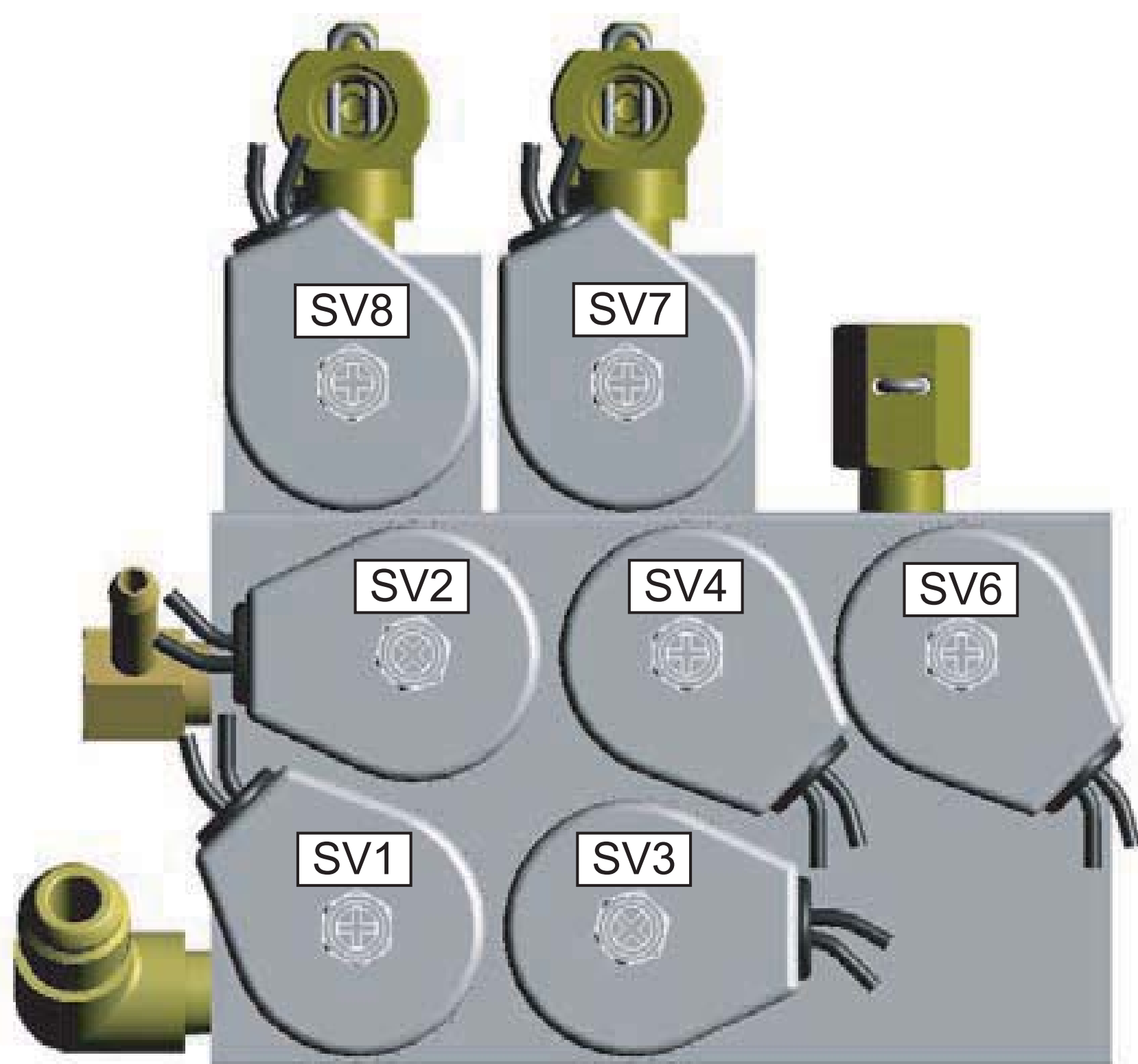

Fig. 6-2 Front View (Faces Pump)

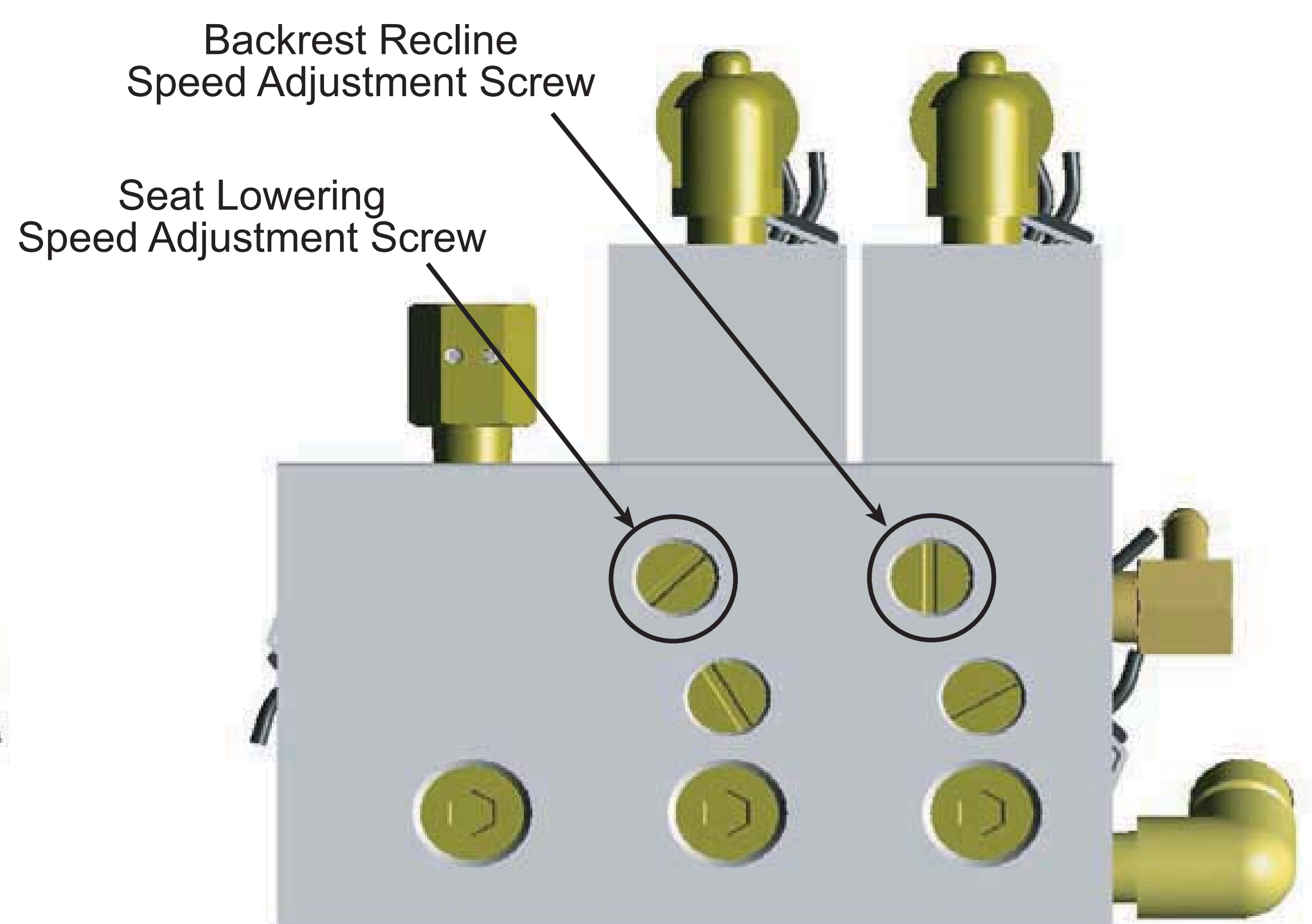

Fig. 6-3 Rear View (Faces Away From Pump)

7. HYDRAULIC DIAGRAM

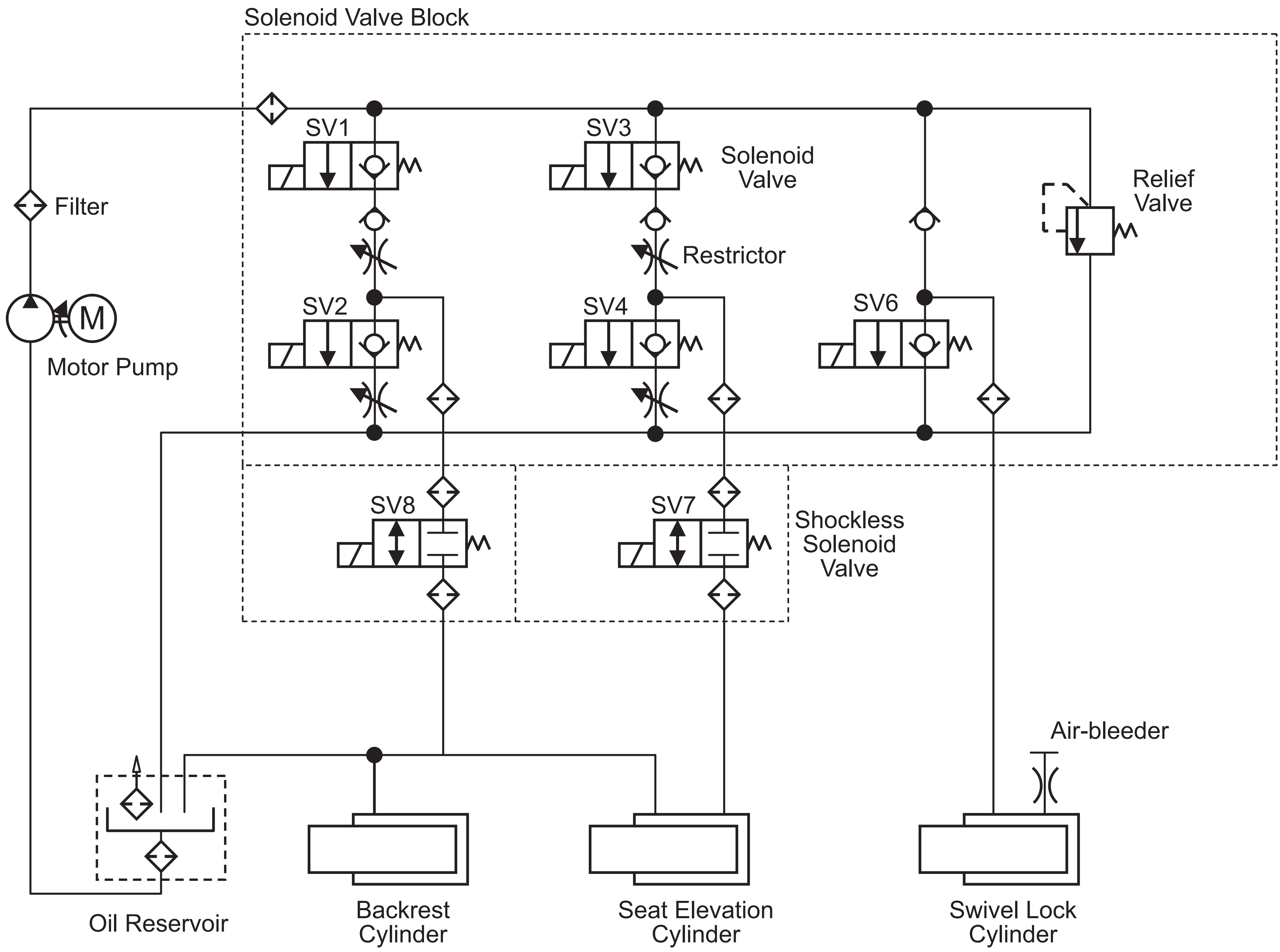
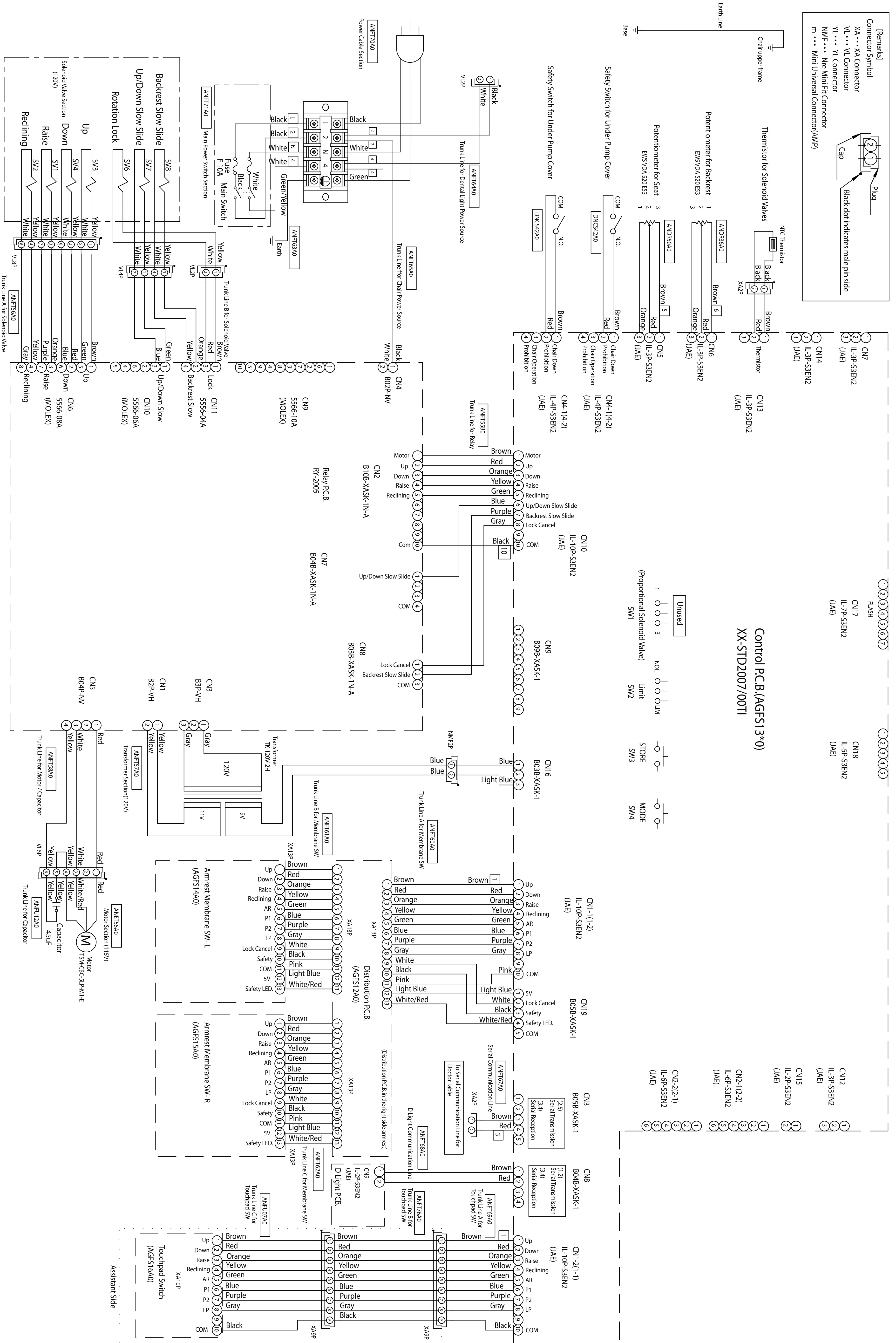
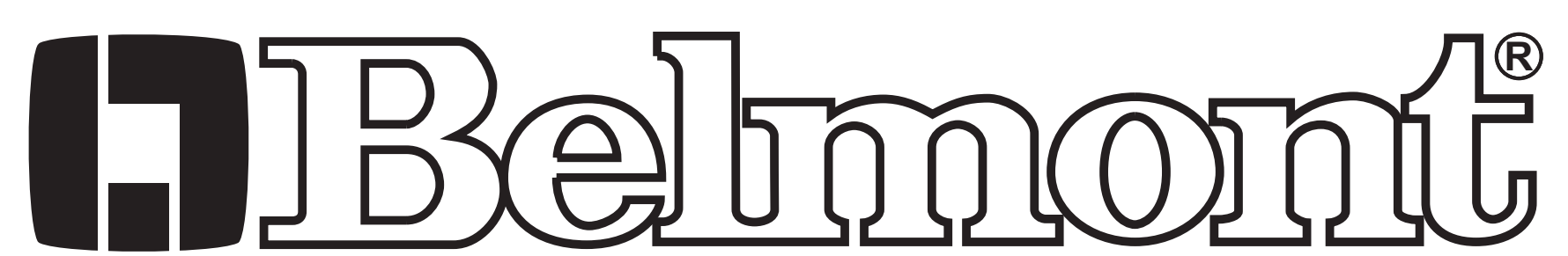

Fig. 7-1 Hydraulic Diagram

8. ELECTRICAL DIAGRAM



NOTE



BELMONT EQUIPMENT, Division of Takara Belmont USA, Inc.

101 Belmont Drive Somerset, New Jersey 08873 U.S.A. TEL.:(732) 469-5000 / (800) 223-1192 Fax.:(732)526-6322 / (800) 280-7504

TAKARA CO, CANADA LTD.

2076 S. Sheridan Way, Mississauga, Ont., L5J2M4, Can. TEL.:(905) 822-2755 Fax.:(905)822-6203